

# Capstan Hoist

- Mobile capstan hoists are used to pull out-of-balance counterweight arbors down for loading
- Fully self contained, the hoist has an integral motor, brake, capstan drum, starter and controls
- Foot switch allows use of both hands to manage the hauling line
- The base has fixed and swivel casters for easy positioning, and a front lip to engage a reaction bar in the locking rail or floor;  
Reaction rail provided separately
- Hoists include 150' (45.75 m) of 3/4" (19 mm) SureGrip<sup>®</sup> rope with a forged safety hook
- Supplied with 40' (12 m) of power cord with NEMA L15-20P plug
- Three-year warranty against defects in materials or workmanship is provided on all J.R. Clancy equipment, additional warranty information is available at jrclancy.com

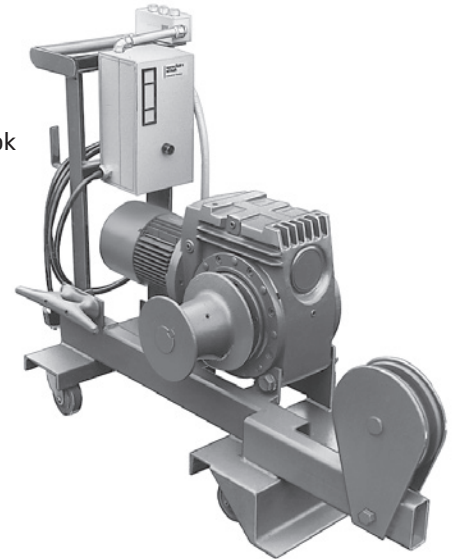

**Mobile Capstan Hoist  
018-416**

## Power Requirements

Model	Voltage	Full Load Amps
3-Phase 60 Hz	208	6.3
3-Phase 60 Hz	230	5.7
3-Phase 60 Hz	460	2.85
3-Phase 50 Hz	380	3.3

## Dimensions

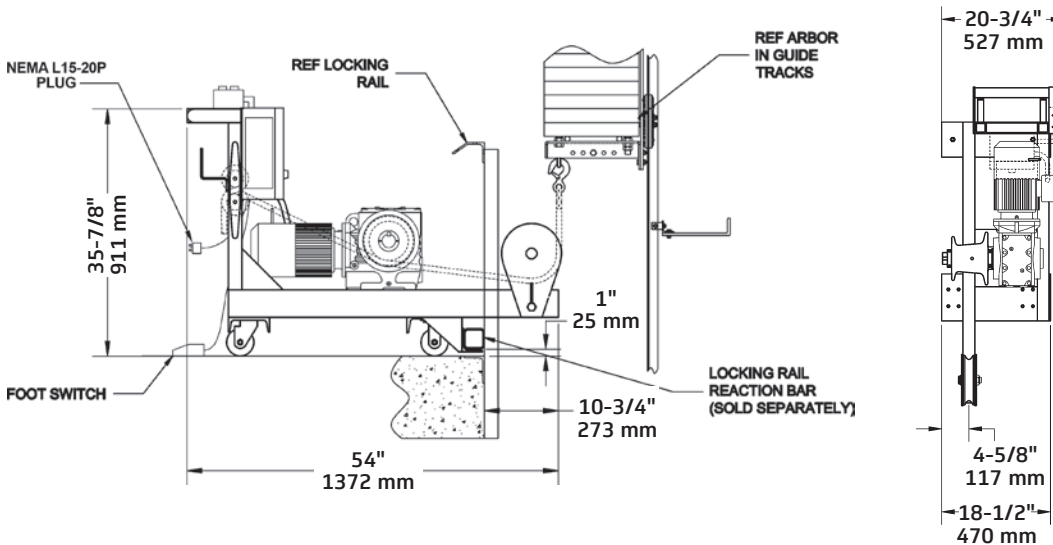

## Order Information

Number	Description	Weight
018-416	Mobile Capstan Hoist 1500 lb (680 kg), 35 fpm (0.178 m/s)	400 lb (181 kg)

